

DROPLET SEPARATOR SYSTEMS FOR FLUE-GAS DESULFURIZATION

The introduction of wet flue-gas desulfurization in Germany is inconceivable without Lechler. As a partner to plant builders, we have made a crucial contribution to success in this area with our development work. The result is nozzles made of highly wear-resistant and corrosion-resistant silicon carbide and droplet separator systems that meet the highest process engineering demands.

Lechler droplet separators are optimally designed for the droplets produced during scrubbing and thus achieve maximum separation levels.

Task:

- Removal of sulfur compounds
- Protection of downstream installation components
- Reduction of operating costs

Advantages:

- Modular system design
- Highest degrees of separation for large liquid quantities
- Separation of small droplets
- Compact design even for high gas speeds
- Low pressure losses
- More uniform flow distribution
- Use also with high solid particle quantities
- Cleaning during ongoing operation
- Delivery of an overall concept
 - Nozzles for desulfurization of flue gases
 - Droplet separator systems
 - Integrated cleaning systems for droplet separators

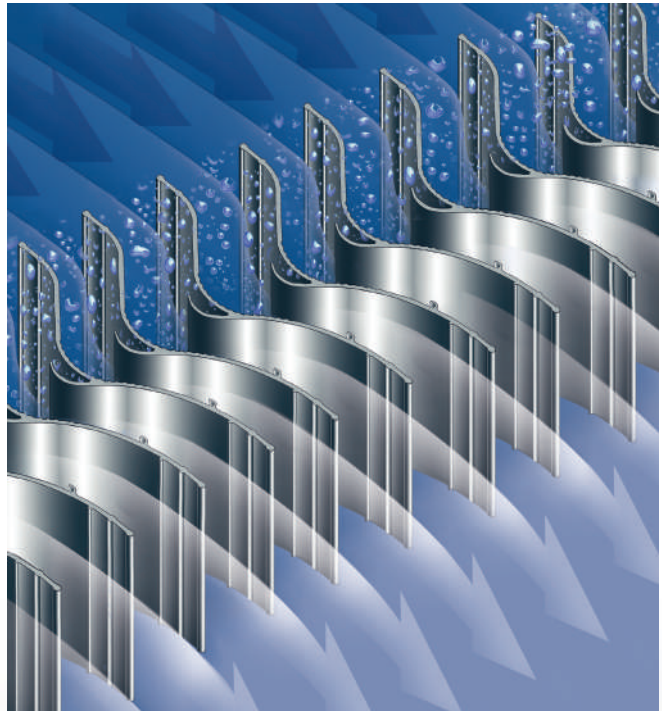

Talk to us

Do you know your process but are not sure which droplet separator is best suited for your purposes? No problem. Based on your individual requirements, we will choose from a finely graded range of vane profiles with single or multiple deflection.

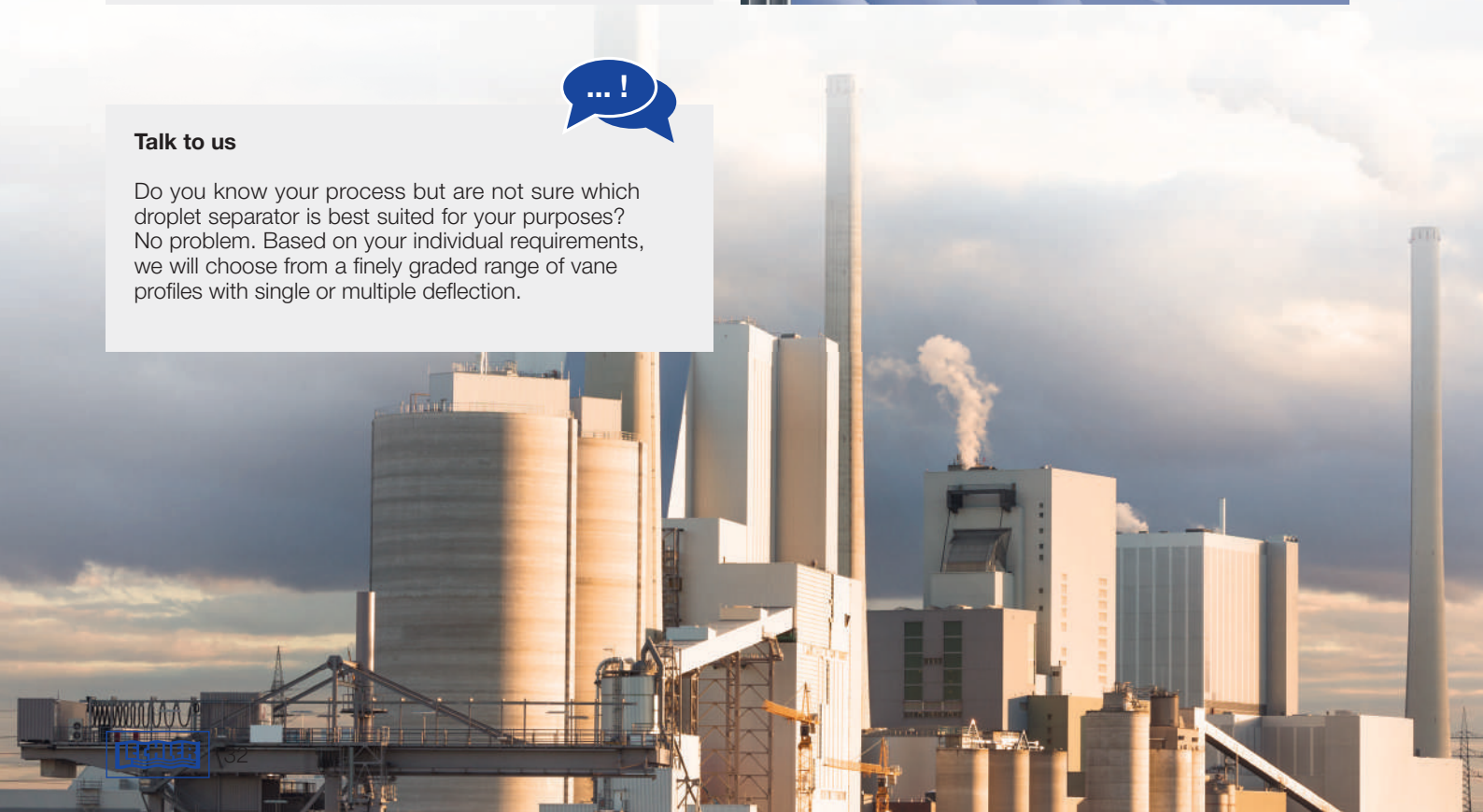

In order to design and plan droplet separators, it is necessary to be familiar with the operating and performance data of the separation systems. An in-depth technical understanding of the processes in each application is also required. Know-how about droplet formation and droplet movement in a gas flow is essential to ensure fault-free operation of a droplet separator. For more than 100 years now, we have worked on detection, measurement and definition of droplets. It is therefore not by chance that Lechler nozzles and Lechler droplet separators are now considered integral elements in process engineering.

Corresponding to the flow direction, Lechler high-performance separators are differentiated based on horizontal and vertical gas flow. Separators are also realized for oblique gas flow under certain conditions. The choice of flow direction depends on the individual process or plant design. Lechler offers a suitable solution for all installation situations.

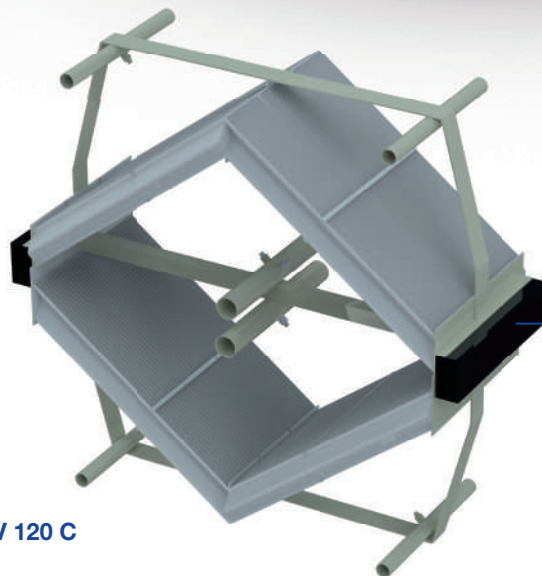
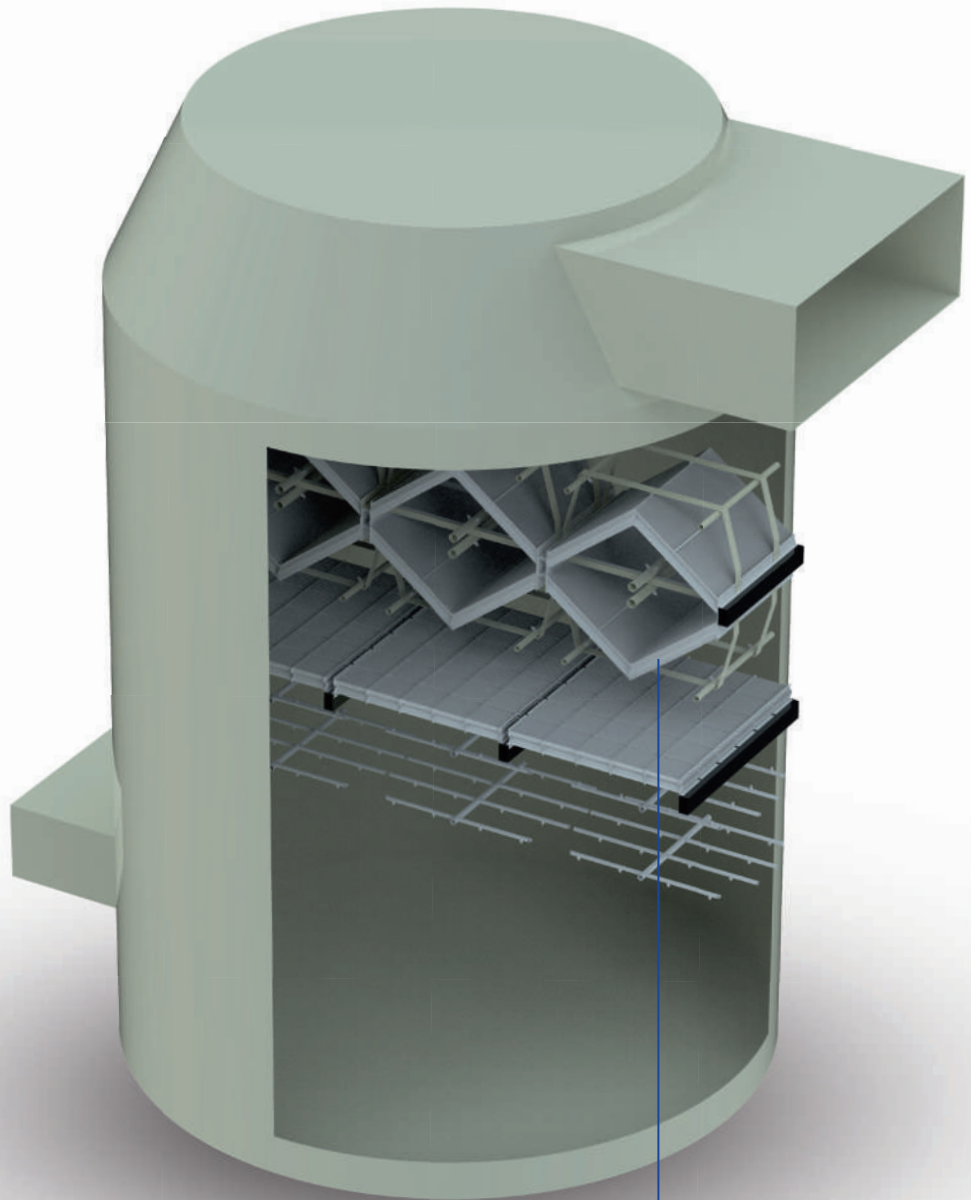

LTV 120 C

DROPLET SEPARATOR SYSTEMS FOR FLUE-GAS DESULFURIZATION

The LTV 120 droplet separator for vertical gas flows is available in different designs and also with multiple stages. Integrated cleaning systems with highly efficient Lechler cleaning nozzles permit continuous operation and reduce the risk of clogging. The angled installation position allows reliable removal of the separated liquid even at high gas speeds.

LTV 120 AA

2-stage droplet separator system with integrated cleaning system for installation on two levels.



LTV 120 C

2-stage droplet separator system with integrated cleaning system for installation on one level. This system is optimized for restricted installation spaces.

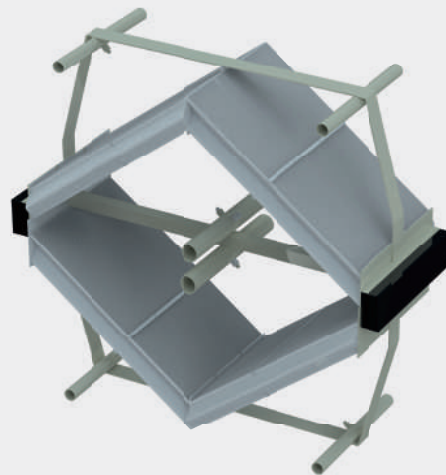

LTV 120 CR

3-stage droplet separator system with integrated cleaning system for installation on two levels. The first separator stage consists of horizontally arranged pipes for pre-separation and flow optimization.

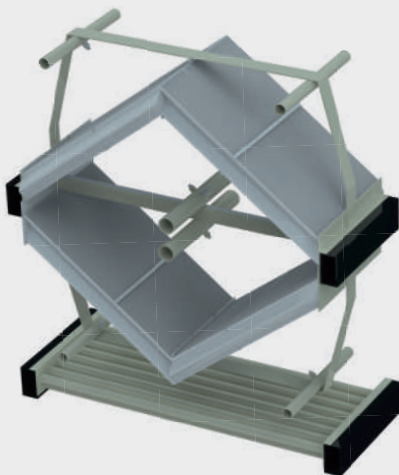

LTV 120 A + LTV 400

2-stage droplet separator system with integrated cleaning system for installation on two levels. The first separator stage consists of the LTV 400 as a flat separator level.

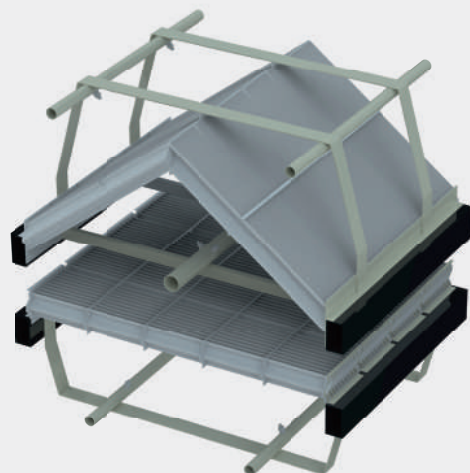

The different droplet separator systems can be combined with each other, depending on individual requirements in relation to efficiency and space.

LTV 400

The LTV 400 is a universal separator system. Thanks to intensive optimization of the profile contour, the LTV 400 achieves high separation values even without additional drainage aids for the separated liquid. The resultant smooth profile surface has a very low fouling tendency and can be cleaned very easily. The LTV 400 can be realized with one or multiple stages and is available with or without cleaning system.

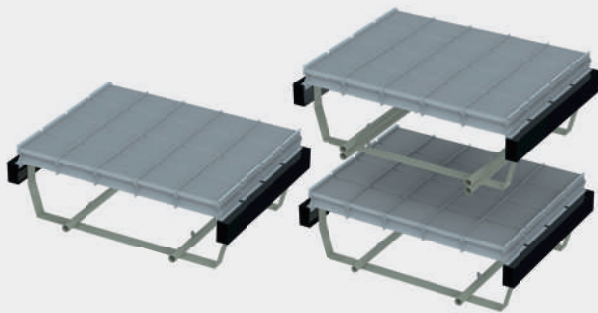

LTV 271

The LTV 271 is a proven, widely used separator system. It also impresses with its straightforward handling and easy adaptation to the existing installation space. The use of our optional "Fix-Clip" connectors prevents packages from slipping.



LTV 300

The LTV 300 is characterized by high separation performance – also for very fine droplets – and an exceptionally high hydraulic load capacity. The special profile geometry and angled installation position permit reliable draining of the separated liquid.



LTH 100

The LTH 100 for horizontal gas flows is characterized by extremely flexible application and combination possibilities. Low pressure loss, high hydraulic load capacity as well as a low fouling tendency make the LTH 100 a universal droplet separator system that has proven itself over the course of many decades.

