

# Billetcooler Oval Spray

## Billetcooler air-mist nozzles

With this nozzle type it is possible to utilise air-mist cooling in billet and bloom casters very effectively. The compact block design allows mounting either on horizontal spray rings but also on vertical nozzle headers. A turn down ratio as wide as 10 : 1 is standard at water pressures between 0.5 and 7 bar at 2 bar constant air pressure provides a wide range of cooling intensities. The oval cone spray footprint provides the option to cool a larger area of the strand with one nozzle spray only thus increasing the cooling efficiency. Various angles for spray width and spray depth are available to compensate for different spray heights and meet the requirements of the individual machine types. Large free passages compared to water only and competitor air-mist nozzles result in a reduced nozzle clogging tendency. Billetcooler oval cone nozzles cover a flow rate range from 0.4 to 12.4 l/min.



Nozzle type	Max. water flow rate	Operating water pressure	Max. air flow rate	Operating air pressure	Spray angle
<b>Billetcooler oval</b>	12.4 l/min	0.5 – 7 bar	12.2 m³/h	1 – 4 bar	60/90 ° (wide) 30/45 ° (deep)

Benchmark data only, individual nozzle data to be specified

### The benefits

- High turn-down ratio (min./max. flow rate) 10:1 (max. 14:1) for high flexibility and extended product (steel grade) mix, reduces the number of different nozzle types in the machine
- Compressed air consumption reduced by appr. 40% for low investment and operation costs
- High Heat Transfer Coefficient (HTC) for high casting speeds

- Compact design ideal for spray rings and vertical headers
- Plate connection for easy and maintenance friendly mounting
- Large free passages prevent clogging for high operation safety with improved plant availability
- Successfully installed in most long product air-mist cooling systems worldwide
- Reduced maintenance costs

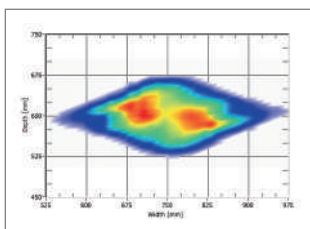
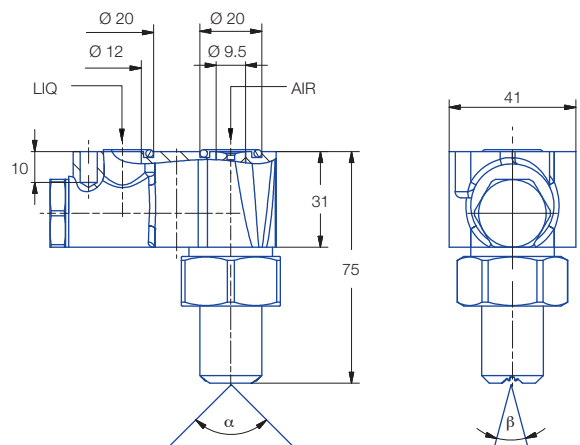

Liquid distribution Billetcooler Oval

